



Twin Roller Tester

TwinRoller-3000



Traction, Roller Contact Fatigue, Wear,
Pure Rolling, Pure Sliding, Combo Rolling Sliding



Research and Quality Control

- Elastohydrodynamic lubrication
- Gear lubricants, materials
- Surface treatments
- Hydraulic fluids
- Pitting
- Rail friction
- Rolling mill
- Sliding-rolling contact
- Traction coefficient
- Traction fluids

Independent Control of Both Rotations

Servo-controlled high torque, precise rotation motors

Wide Load Range - Nano and Micro

Load cells with forces from 1 N to 8000 N

In-line 3D Optical Inspection

Generate sub-nm 3D images of the surface during the test

Environmental Control

Control temperature with high-resolution controllers

Custom Sample Holders

Unique design to allow for wide sample sizes

Two Independently Controlled High Speed Rollers

Several In-line Sensors to Monitor Real Time Surface Interactions

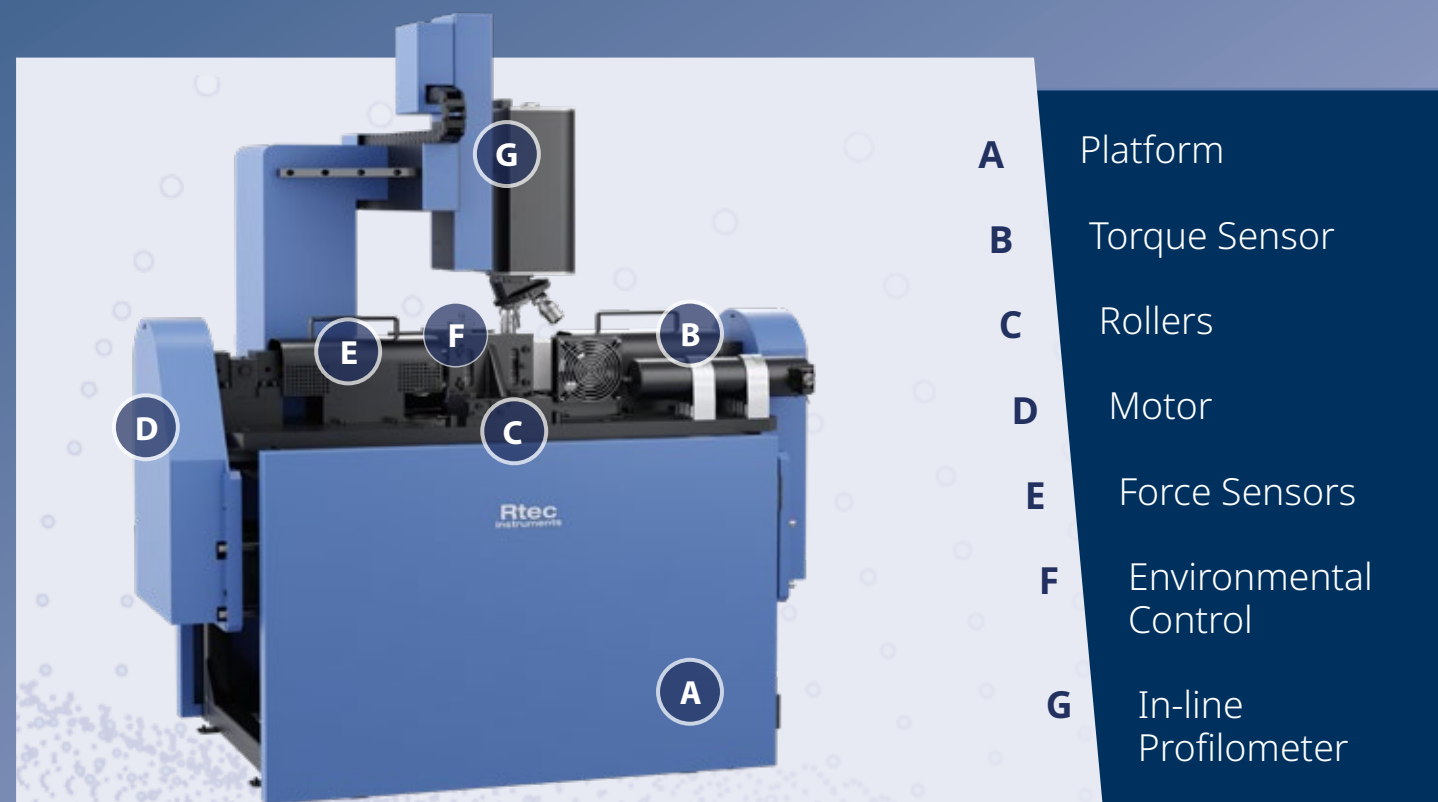

Automation and Analysis

Introduction

Rtec-Instruments' TwinRoller-3000 is an ideal twin roller machine to study traction, wear, and rolling contact fatigue under various combinations of rolling and sliding. The tester comprises two high torque independently controlled servo motors with an open platform architecture that allows easy access. Force is applied using electro-servo drives. The tests are done under controlled environmental conditions and run dry and lubricated setups. Lubricants can be contained in a container or circulated during the test. Fully automated test programs and advanced controllers allow high repeatability and precision measurements.

Active Feedback Loop Control

The tester comes with closed-loop active feedback controls over many parameters. The rotation speed is controlled using servo-controlled feedback, allowing testing at constant or changing RPM. The applied force is controlled during the test using electro servo drives. The force is measured using high precision force sensors with negligible drift, all while operating at constant or linear changing force profiles. The tester comes with several environmental control options. The advanced temperature controller allows temperature measurement at multiple points simultaneously.

Accurate determination of failure events

The tester can accommodate various in-line monitoring sensors to quantify real-time surface

dynamics. A few commonly used sensors are:

a) Torque Sensor - Patented high-resolution in-line dynamic torque sensor to monitor change in generated frictional forces.

b) Acoustic Emission - Wide frequency sensors to detect crack initiation points during the test.

Ease of use and automation

The instrument comes standard with a powerful set of software, including tester control, post-analysis, and imaging. Each test can be controlled by a series of command blocks forming a protocol or "recipe." The data can be export into many formats, including ASCII format.

The software allows the user to stop the test using logic based on signals from several in-line sensors. For example, the user can put the stop test condition as - "When friction increases by 30% or when the acoustic sensor shows a failure initiation signal, stop the test". This condition allows the user to do a post-analysis of the sample the moment failure starts to happen.

The TwinRoller-3000 has advanced high speed, low noise, fast feedback, multiple channels, and the highest data acquisition rate (200 kHz) controllers.

Applications

Broad testing conditions allow the TwinRoller-3000 to be used across several applications such as automotive, aerospace, lubricant, railways, coatings, EV vehicles, motors, turbines, and much more.

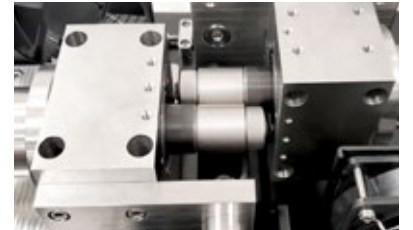

2 Rollers During A Test

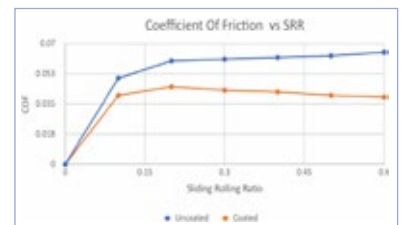

Data Showing Friction vs. Sliding Rolling Ratio



Top View of the TwinRoller-3000



Software Interface

Platform Specification

Loading Stage

- Motion resolution: 0.1 μm
- Maximum speed: 1 mm/s

Load

- Max load: 5000 N / 8000 N*

Computer console

- Latest Windows OS
- LCD monitor
- 16 bit data acquisition

*Higher ranges available

Additional Sensors

- Acoustic emission
- Eddy current
- In-line Wear
- Potentiostat

Rotary Drive

- Pure rolling
- Pure sliding
- 0-200% Sliding/rolling ratio
- Standard torque 60 Nm*
- Standard speeds up to 3000/6000 RPM*
- 30 to 60 mm diameter*

Facilities Requirement

- Power Requirements:
220 / 380 / 480 VAC

Environmental

- -35 °C to 150 °C
- Dry or with liquids



▲ Rtec-Instruments Office

● Agent / distributor

Rtec-Instruments Inc

USA

1810 Oakland Road, Ste B
San Jose, CA, 95131, USA
☎ +1 408 708 9226
info@rtec-instruments.com

Rtec-Instruments SA

EMEA

Chemin des Taborneires 4 (Box 115)
1350 Orbe, Switzerland
☎ +41 24 552 02 60
info.eu@rtec-instruments.com

Rtec-Instruments, CN

China

8th Floor, Building A, Juntai International, No. 300
Xicheng Rd, Jianye District, Nanjing, China, 210019
☎ +86 025 83210072
info@rtec-instruments.cn

Rtec-Instruments, JP

Japan

Tokatsu Techno Plaza, Rm 409
5-4-6 Kashiwanoha, Kashiwa-shi,
Chiba, Japan, 227-0882
☎ +81 50 5896 9916
info.jp@rtec-instruments.com



www.rtec-instruments.com

TwinRoller-3000-2025-B-01A-EN

2025 Rtec-Instruments Product Catalogue.
All rights reserved.
All specifications are typical and subject to change without notice.